

OEM rubber pad  
Rear plastic with molded 6mm nuts

Remove (3) OEM rear pad bolts. Place steel rack with (3) spacers on top of the OEM pad. Using the (3) long 6mm bolts, start into the rack and into the OEM molded nuts, do not install completely, start only. You may need to remove the (2) 10mm bolts that secure the rear fender to the tail light bracket for ease of access. Place (2) carriage bolts down through triangle shaped plate with the threads pointing towards the ground. This assembly goes under the rear fender but on top of the steel frame under the fender and aligns with the molded OEM nuts. Now you can tighten the long 6mm bolts from the top and they should protrude through the OEM molded nuts and through triangle plate assembly. Secure with the (3) provided 6mm nuts. Secure the half clamp to the OEM crossbar with the locking nuts provided onto the carriage bolts.

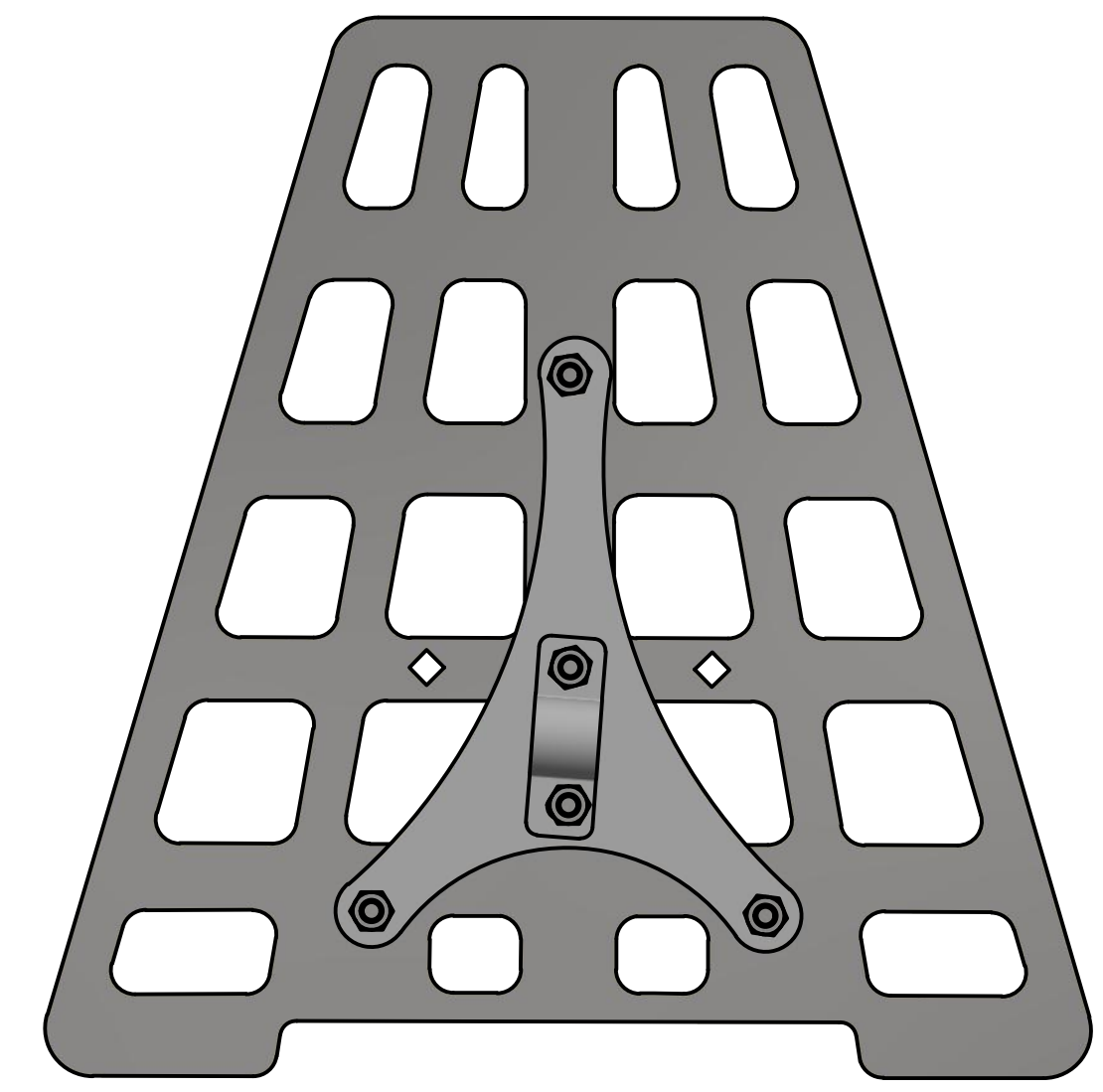
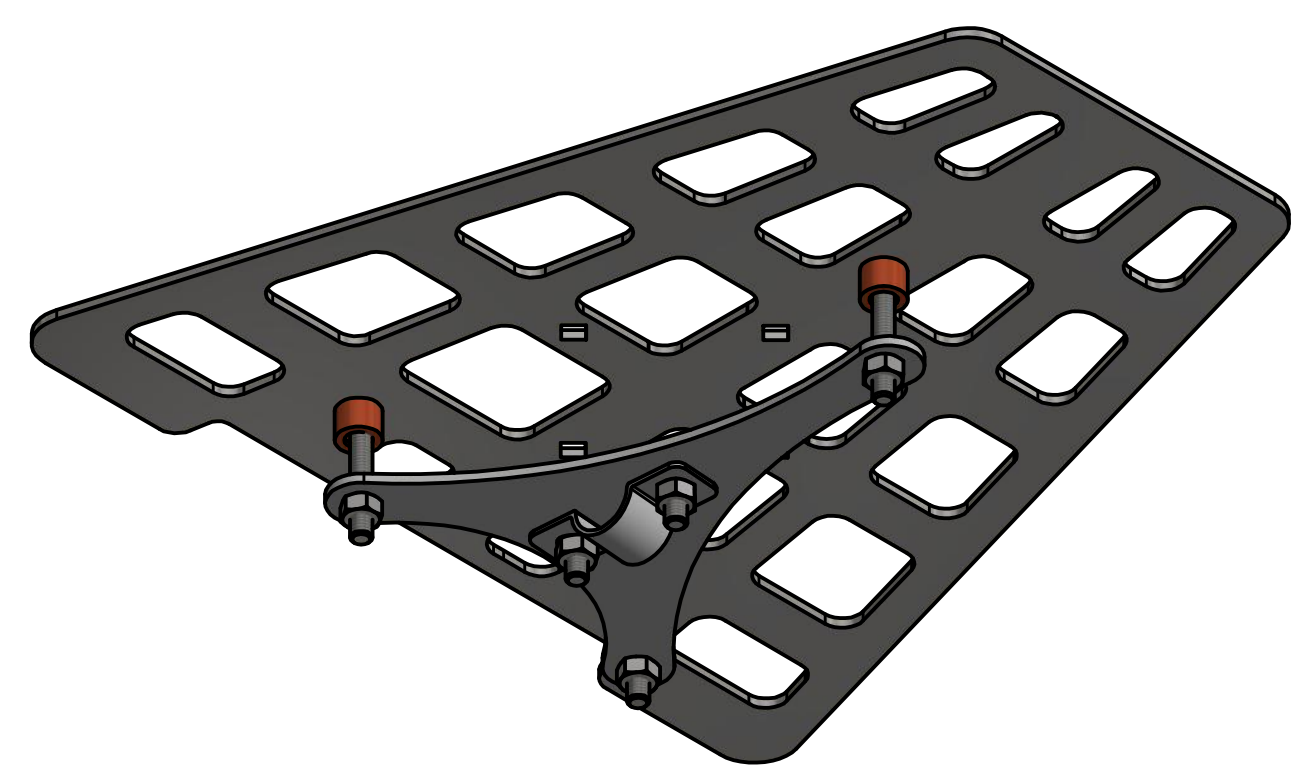
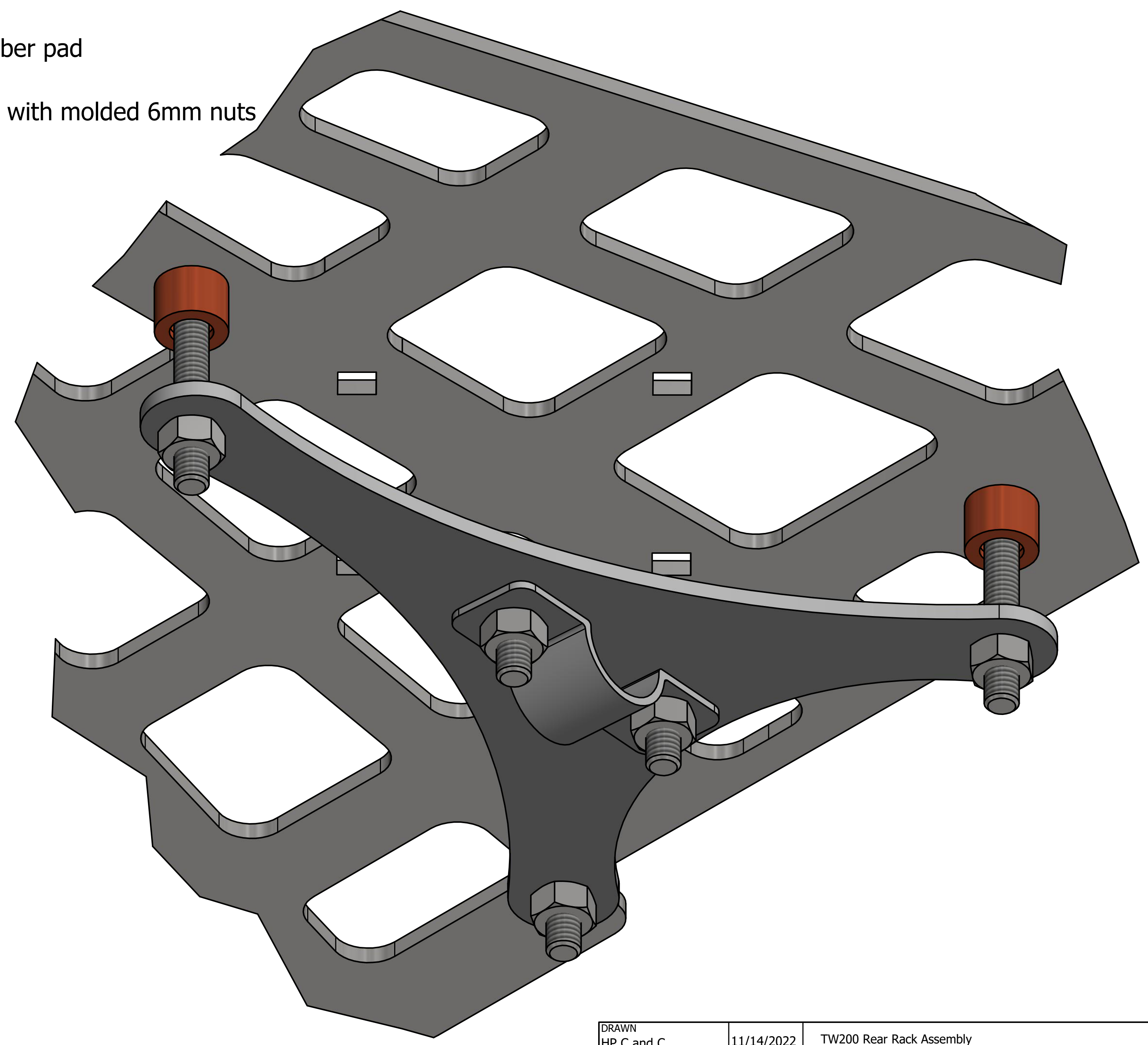

DETAIL A  
SCALE 2 : 1

DRAWN HP C and C	11/14/2022	TW200 Rear Rack Assembly	
CHECKED		TITLE	
QA			
MFG			
APPROVED			
		SIZE D	DWG NO TW rear rack assy
		SCALE 1 / 2	REV SHEET 1 OF 1